

J.L. WINGERT CO.

Specification Sheet TOWER BASIN EDUCTORS MODELS TBE-[]

SS052056.B 03/16

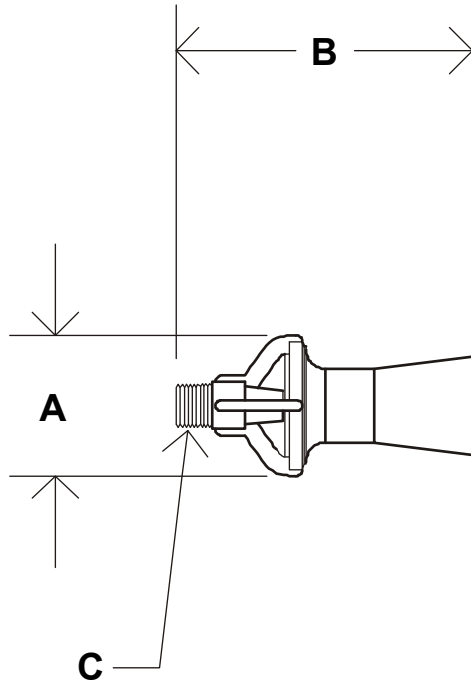

SPECIFICATIONS:

EDUCTOR: Polypropylene, 5:1 flow eductor in 1/4", 3/8", 3/4", 1" and 1 1/2" NPT

FLOW RATES - GPM (M³/MIN)

PSI/BAR	TBE-025	TBE-038	TBE-075	TBE-100	TBE-150
10 / 0.69	3.2 (0.012)	7.5 (0.028)	13.5 (0.051)	21 (0.079)	33 (0.125)
15 / 1.03	3.9 (0.015)	9.2 (0.035)	16.5 (0.062)	26 (0.098)	40 (0.151)
20 / 1.38	4.5 (0.017)	10.6 (0.040)	19.1 (0.072)	30 (0.114)	47 (0.178)
25 / 1.72	5.0 (0.018)	11.9 (0.045)	21 (0.079)	33 (0.125)	52 (0.197)
30 / 2.07	5.5 (0.021)	13 (0.049)	23 (0.087)	36 (0.136)	57 (0.216)
35 / 2.41	5.9 (0.022)	14 (0.053)	25 (0.095)	39 (0.148)	62 (0.235)
40 / 2.76	6.3 (0.024)	15 (0.057)	27 (0.102)	42 (0.159)	66 (0.250)
50 / 3.45	7.1 (0.027)	16.8 (0.064)	30 (0.114)	47 (0.178)	74 (0.280)

DIMENSIONS:

KEY	TBE-025	TBE-038	TBE-075	TBE-100	TBE-150
A	1 1/2"	2 1/8"	3"	3 3/4"	4 5/8"
B	3 1/8"	4 1/2"	6 3/8"	8 1/2"	9 7/8"
C	1/4" MPT	3/8" MPT	3/4" MPT	1" MPT	1 1/2" MPT

Note: All dimensions are +/- 1/8". All weights are approximate. All dimensions are subject to change without notice.

MANUFACTURING: Mixers, Bypass Feeders, Filter Feeders, Bromine Feeders, Sample Coolers, Sludge Traps, Separators, Separator Systems, Tank Stands, Tank Package Systems, Glycol Feed Systems, Coupon Racks, Control Stations, NEMA Enclosures, Custom Packaged Systems and Specialty Welding

P.O. Box 6207 | Garden Grove, CA 92846-6207 | 11800 Monarch St. | Garden Grove, CA 92841-2113 | Phone (714) 379-5519 | Fax (714) 379-5549
Northern California Region | Phone (510) 487-5310 | Southwest Region | Phone (602) 470-1015 | Email: customerservice@jllwingert.com

www.jllwingert.com